

ACE-G6I-155BCP Emergency LED Driver



ACE-G6I-155BCP EMERGENCY LED DRIVER

CEA C22 No. 54, Emergency Lighting Equipment, Appareil d'éclairage de secours, Made in Taiwan - ASITRO

- Input Voltage: 120-277 V @ 50/60 Hz
- Input Current (max): 110 mA
- Input Power: 8 W
- Output Voltage: 15-55 V¹
- Output Current: 109 mA - 400 mA
- Output Power: 6 W
- Battery Voltage: 6.4 V
- Battery Charge Current: 185 mA
- Battery Charge Time (max): 24 hrs
- Operating Duration (min): 90 min
- Ambient Temperature: 0 °C - 55 °C
- Output Class 2 Compliant
- Suitable for damp locations
- Full Battery of Field Installation
- For metal enclosed wiring system

CAUTION: See instruction manual for installation, opening, and maintenance procedures. Service by Qualified Personnel Only. De-energize before opening. Sealed unit. BATTERIES (if applicable). Dispose units when necessary.

ATTENTION: Not suitable for air handling or heated air outlets.

800-375-6355

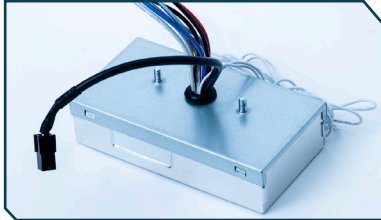

Accessories sold separately:

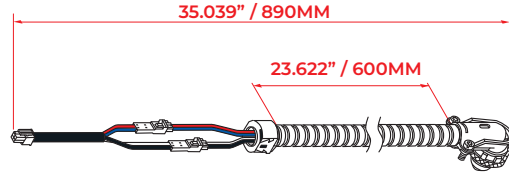

Right angle test switch with conduit.
Model #: 10220600-04RA



Chrome test switch, 12mm
Model #: 10220176-05

Primary Specifications:

Output Power Max	Input Power MAX	Input Current Max	Emergency Operating Time	Battery	Input Voltage	Output Voltage	Ambient Operating Temperature	UL Listed for US and Canada
6 W	8 W	110 mA	90 min.	LiFePO ₄ 24 Hour recharge 7 to 10 year Life expectancy	120-277 Vac 50/60Hz	15-55 V ¹	0 °C through 55 °C	UL and cUL (UL924) Emergency LED Driver

Description:

The **ACE-G6I-155BCP** from AC Electronics is a UL Listed Emergency LED Driver that enables the same LED fixture to be used for both normal and emergency operation. The **ACE-G6I-155BCP** contains a Lithium iron phosphate battery, a high-efficiency battery charger, control circuitry, and high-efficiency power converter circuits, in a single metal enclosure. In the event of a normal power failure, the **ACE-G6I-155BCP** switches to emergency-mode and operates the fixture's LED array or module for 90 minutes at a constant power of 6 W. When normal power returns, the **ACE-G6I-155BCP** returns to normal-mode. The **ACE-G6I-155BCP** can be used in switched or unswitched fixture applications. **The ACE-G6I-155BCP** can drive any LED array or module in emergency-mode with a voltage range of 15-55 Vdc and that can operate at a current range of 109 mA to 400 mA.

Safety and Regulatory Compliance:

- UL and cUL Listed as an Emergency LED Driver (UL924)
- UL Listed for both field and factory installation
- UL & cUL Class 2 output (UL1310 compliant)
- CEC Title 20 compliant: Certified in CA Title 20 Appliance Efficiency Database – Battery Charger
- EMI: Complies to FCC commercial limits
- RoHS compliant

5-Year USA-Backed Warranty*

See complete AC Electronics/ACE LEDS Warranty information for details.

Additional Specifications:

Normal (ac) driver maximum output current:.....5 A²
 Output current range:.....109 mA to 400 mA³
 Surge protection:3 kVp
 Maximum case temperature Tc:66 °C
 Nominal battery voltage:.....6.4 V
 Battery charge current:185 mA
 Storage time (max) and storage temperature:12 months 0 °C to 35 °C
 Metal enclosure IP rating:.....IP30
 Weight.....0.7 lb
 Dimensions:.....4.57 in L x 2.48 in W x 1.18 in H

¹The emergency-mode output voltage operating range is 15 - 55 V. The absolute maximum output voltage is 60 V to comply with class 2 regulations.

²The Normal (ac) Driver maximum output current is the maximum current allowed to pass through the **ACE-G6I-155BCP** circuitry in Normal-mode.

³The emergency-mode output current is automatically adjusted to maintain a constant output power across the output voltage range.

*Warranty: 5 years based on a maximum case temperature of ≤ 60 °C, 3 years warranty based on a maximum case temperature of ≤ 66 °C

For questions or to place an order contact us at oemsales@aceleds.com or 800-375-6355 or your local WPG Americas Sales representative at inquiry@wpgamericas.com or 888-WPG8881

ACE-G61-1555BCP EMERGENCY LED DRIVER

CSA C22.2 No. 347, Emergency Lighting Equipment
Appareil d'éclairage de secours
Made in Taiwan - AMTHHO

- Input Voltage: 120-277 V, 50/60 Hz
- Input Current (max): 110 mA
- Input Power: 8 W
- Output Voltage: 15-55 V
- Output Current: 109 mA - 400 mA
- Output Power: 6 W
- Battery Voltage: 6.4 V
- Battery Charge Current: 185 mA
- Battery Charge Time (max): 24 Hrs
- Operating Duration (min): 90 min
- Ambient Temperature: 0-55 °C
- Output class 2 compliant
- Suitable for damp locations
- For factory or field installation
- For metal enclosed wiring system

CAUTION: See instruction manual for installation, operating, and maintenance instructions. Service by Qualified Personnel Only. De-energize before opening. Sealed unit. BATTERY not replaceable. Replace entire unit when necessary.

ATTENTION: Not suitable for air-handling or heated air outlets.

ACE LEDS
800-375-6355

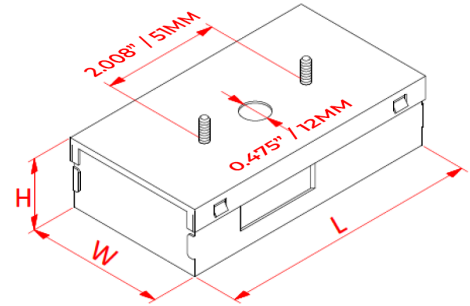
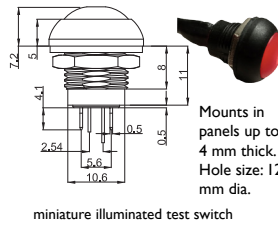

Lead Lengths					
Black/White	6"	White/Red	6"	Test Switch/	7.08"/
Black/White	6"	White/Blue	6"	LED Indicator	23.62"
White	6"	Red	6"	Battery Connector	33.07"
Yellow/Black	6"	Blue	6"		

Dimensions / Weight			
Length	4.57"	Height	1.18"
Width	2.48"	Weight	0.7 lb

Constant output power performance over full 90 minutes run-time

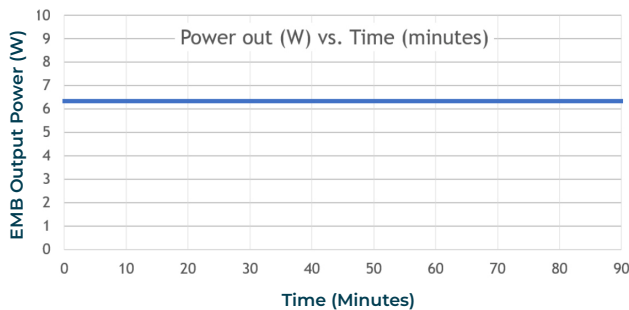

Constant output power performance over full output voltage range

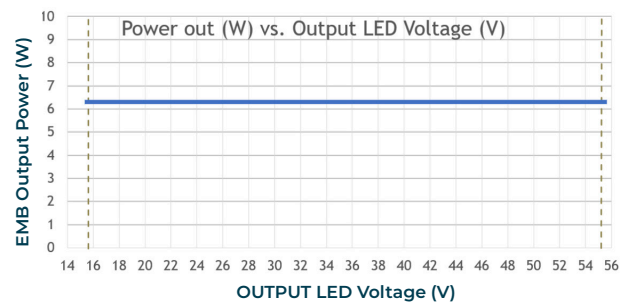

Features, Benefits, and Applications:

- Constant output power: Maintains constant emergency light levels over the full 90-minute runtime and over the output voltage range.
- Self-sensing output voltage: Automatically adjusts over the 15-55 V range to maintain constant power within the class 2 voltage range.
- Includes input over voltage surge protection, output short circuit, open circuit, and over-voltage protection, as well as over-temperature protection for improved reliability.
- Two-wire universal input: Reduces wiring errors and reduces installation time and complexity.
- Includes a miniature illuminated test switch status indicator: Enables mounting in small spaces.
- Suitable for indoor and damp locations.
- Compatible with a variety of LED fixtures, such as emergency-only fixtures, as well as new and existing fixtures.
- Includes an isolated AC power relay which is used to provide a delay of the applied AC power to the normal AC LED DRIVER upon transition from emergency-mode to normal mode.

Specifications:

Emergency lighting shall be provided by using the AC Electronics **ACE-G61-1555BCP** Emergency LED Driver with a compatible LED fixture. The **ACE-G61-1555BCP** shall contain a LiFePO₄ battery with a nominal voltage of 6.4 V and 2000 mAh capacity, a high-efficiency battery charger, control circuitry, a high-efficiency two-wire universal input converter (120 through 277 Vac), high-efficiency output LED driver with soft-switching technology to prevent noise to protect LED modules, all contained in a single metal enclosure. A separate miniature illuminated test switch status indicator with installation hardware shall be provided for the purposes of performing periodic testing and indicate status change of the battery and battery-charger. The **ACE-G61-1555BCP** Emergency LED Driver shall be capable of delivering a constant power of 6 W to an LED load of 15 – 55 V for a minimum of 90 minutes. The **ACE-G61-1555BCP** Emergency LED Driver shall have a maximum of 8 W input power and shall comply with emergency standards established by the current NEC and shall meet CEC Title 20 (California Energy Commission) efficiency standards. The **ACE-G61-1555BCP** Emergency LED Driver shall comply with part 15 of the FCC Rules. The **ACE-G61-1555BCP** Emergency LED Driver shall be UL Listed for field or factory installation. The **ACE-G61-1555BCP** is suitable for indoor and damp locations.

For questions or to place an order contact us at oemsales@aceleds.com or 800-375-6355 or your local WPG Americas Sales representative at inquiry@wpgamericas.com or 888-WPG8881

Installation:

The **ACE-G6I-1555BCP** Emergency LED Driver may be used with either a switched or unswitched fixture. If used with a switched fixture, an unswitched (constant hot) lead must be connected to this emergency LED driver to allow the battery to charge properly and to maintain a charge when normal AC power is available. The emergency LED driver must be fed from the same branch circuit as the normal AC LED driver (if used). This emergency LED driver must not be installed with fixtures where the ambient temperature may fall

below 0 °C (32 °F), and it must be installed inside an electrical enclosure. The **ACE-G6I-1555BCP** Emergency LED Driver comes in a single metal enclosure with a separate miniature illuminated test switch status indicator. This emergency LED driver is suitable for installation in sealed and gasketed fixtures. The maximum remote mounting distance to the LEDs is 18 feet. The emergency LED driver metal case should be grounded. 18 AWG 600 V, 105 °C tinned stranded copper lead-wires are required for installation.

Typical wiring diagram for switching the switched hot AC power for the normal AC LED Driver

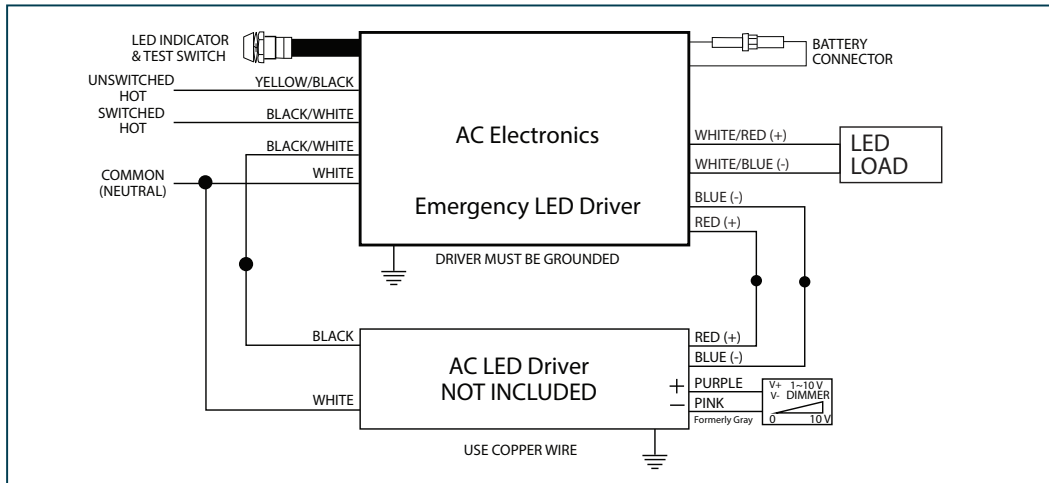

Typical wiring diagram for switching the neutral wire of the normal AC LED DRIVER

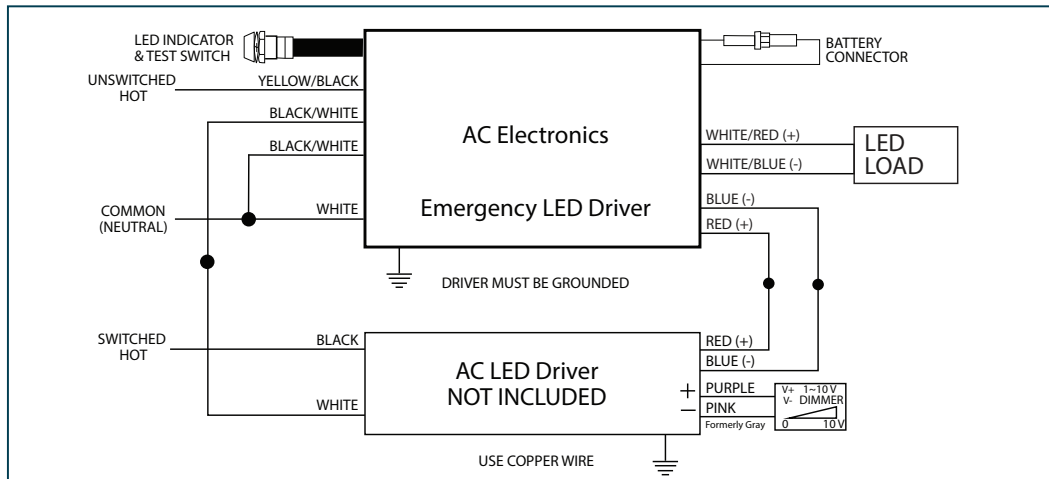

*AC Electronics/ACE LEDS warrants to the purchaser that each Emergency LED Driver will be free from defects in material or workmanship for a period of 5 years when operated at max case temp of up to <60°C when properly installed and under normal conditions of use. See aceleds.com for complete warranty policy.

For questions or to place an order contact us at oemsales@aceleds.com or 800-375-6355 or your local WPG Americas Sales representative at inquiry@wpgamericas.com or 888-WPG8881