

ACI-G25-A1 Emergency Lighting Inverter



Primary Specifications:

Input Voltage	Input Current Max	Input Power Max	Output Voltage	Output Power Max	Emergency Operating Time	Ambient Operating Temperature	UL Listed for US and Canada
120-277 Vac 50/60Hz	120 mA	14 W	120/277 Vac	25 W (PF: 0.65 leading to 0.65 lagging)	90 minutes minimum	0 °C through 50 °C	UL and cUL (UL924) Emergency Lighting Power Supply

Note: All specifications valid over ambient operating temperature range unless otherwise noted.

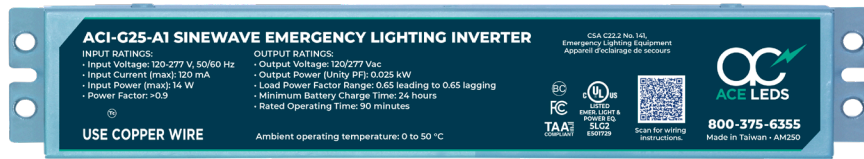

Description:

The **ACI-G25-A1** from ACE LEDS is an emergency lighting inverter with a pure sine wave output, capable of delivering 25 Watts to the lighting load. The **ACI-G25-A1** contains a high-performance, emergency power grade, long-life lithium iron phosphate (LiFePO₄) battery, a high-efficiency smart battery charger and battery safety management system, control circuitry, and a high-efficiency pure sine wave power inverter. The **ACI-G25-A1** includes a 0-10 Vdc Automatic Dimming control feature, which expands its compatibility and operational capabilities. The **ACI-G25-A1** is compatible with LED, fluorescent, and incandescent fixtures. The **ACI-G25-A1** comes in a single metal enclosure with flexible metal conduit and hardware. In the event of a normal power failure, the **ACI-G25-A1** automatically switches

to emergency-mode delivering emergency power to the connected load for a minimum of 90 minutes. When normal power returns, the **ACI-G25-A1** returns to normal-mode. The **ACI-G25-A1** can be used in switched or unswitched or emergency-only fixture applications. The **ACI-G25-A1** features the capability to meet high load inrush current (I²t) demands, as well as high start-up power demands. The small physical size, wide ambient temperature operating range, and robust power delivery capability allows the **ACI-G25-A1** to be used with existing fixtures for both normal-mode operation and emergency-mode operation, while maintaining the aesthetic design of the fixture and lighting space.

Additional Specifications:

Input Voltage: 120 – 277 Vac, 50/60 Hz, (Universal Input)
 Input Current: 120 mA (max)
 Input Power: 14 W (max)
 Input Power Factor: > 0.9
 Inrush current: < 20 Apk.
 Surge Immunity: 6 kV Ring wave and Combination wave
 (Per ANSI/IEEE C62.41.2-2002)
 Output voltage: 120/277 Vac (+/- 5%), (auto select), 60 Hz (+/- 3 Hz)
 Output Power Rating: 25 Watts max (valid over a load PF range from 0.65 leading to 0.65 lagging)
 VA max: 38.5 VA
 Inverter overload capability: 42.3 VA for 100 minutes
 Output voltage waveform: Pure sinewave (resistive load)
 Output current THD: Less than 3% (resistive load)
 Compatible lighting loads: LED, Fluorescent, Incandescent
 Output Short Circuit Protection: Auto Recovery (10 Seconds)
 Operating ambient temperature: 0 °C to 50 °C
 Humidity: 10% to 90%
 Maximum case temperature Tc: 70 °C
 Nominal battery voltage: 12.8 V

Battery charge current: 500 mA
 Battery charge time: 24 hours
 Metal enclosure IP rating: IP30
 Remote distance: 1000 ft. using 18 AWG wire (Remote distance from inverter to load is limited by the losses in the wire.)
 Emergency operating time: 90 minutes minimum
 Transfer time: 2.0 sec. (transfer from normal to emergency mode)
 Configurations: Switched, unswitched (always on), or emergency-only (normally off)
 Weight: 4.4 lbs. (2 kg)
 Dimensions: 20.67 in L x 2.24 in W x 2.17 in H
 Mounting: 20.28 in
 MTBF: 100,000 hours @25 °C Ta
 Lifetime: 75,000 hours (under normal use @50 °C Ta)
 Storage time (max) and Storage Temperature : 12 months (0 °C to 35 °C)
 Power Cycle endurance capability: 10,000 on/off cycles, 1 s on, 1 s off, @25 °C Ta
 Over temperature protection: Automatic shut down

For questions or to place an order contact us at oemsales@aceleds.com or 800-375-6355 or your local WPG Americas Sales representative at inquiry@wpgamericas.com or 888-WPG8881

Safety and Regulatory Compliance:

- UL and cUL listed (UL924), USA and Canada, for both field and factory installation.
- cUL listed to CSA C22 No.141
- Warranty: 5 years based on a maximum case temperature of $\leq 60^{\circ}\text{C}$, 3 years warranty based on a maximum case temperature of $\leq 70^{\circ}\text{C}$
- Includes an integrated charging indicator LED and test switch
- CEC Title 20 compliant: Certified in CA Title 20 Appliance Efficiency Database – Battery Charger
- EMI: Complies to FCC Part 15 class A

Features, Benefits, and Applications:

- Includes a 0-10 Vdc Automatic Dimming control feature, which expands its compatibility and operational capabilities.
- Maintains output voltage regulation over the full 90-minute runtime.
- Includes input over voltage surge protection, output short circuit protection, and over-temperature protection for improved reliability
- Two-wire universal input: Reduces wiring errors and reduces installation time and complexity
- Automatically selects the appropriate output voltage (120/277 Vac)
- Pure Sine Wave output waveform: Provides improved reliability of connected driven loads, reduces heat, improves efficiency, and provides optimum compatibility across all lighting load types.
- Capable of sourcing high crest factor loads.
- High load inrush current (I^2t) capability.
- High start-up power delivery capability: Provides robust and smooth start-up for the most demanding luminaire loads.
- Wide load power factor range: (0.65 leading to 0.65 lagging)
- UL and cUL listed.
- Includes a miniature illuminated test switch status indicator.
- Suitable for indoor and damp locations.
- Compatible with LED, Fluorescent, and Incandescent lighting fixtures
- Compatible with AC line voltage driven TLEDs
- Small size and versatile mounting.
- High efficiency: No fans required.
- Versatile output wiring configuration options: Normally On, Normally Off (Emergency only), or Switched.
- Galvanized steel enclosure with 36-inch flexible metal conduit.
- Test switch wiring can be extended up to 50'.
- RoHS compliant.

Operation:

Under normal-mode conditions, the **ACI-G25-A1** allows normal operation of the connected Normal AC lighting fixture. The maximum load power during normal-mode is 75 Watts. Also, under normal-mode conditions, the **ACI-G25-A1** charges and maintains the internal LiFePO_4 battery. In the event of a normal power failure, the **ACI-G25-A1** automatically switches to emergency-mode and delivers emergency power to the connected Normal AC lighting fixture(s) for up to 90 minutes or until normal power returns, whichever comes first. When normal power returns, the **ACI-G25-A1** returns to normal-mode.

The smart controls and battery management system prevents the battery from being deep discharged during prolonged power outages.

Automatic Dimming:

The **ACI-G25-A1** features an automatic dimming control (0-10 Vdc) circuit that greatly expands the utilization of this Emergency Lighting Inverter. When the inverter's 0-10 Vdc dimming circuit is connected to the 0-10 Vdc dimming control input of a 0-10 Vdc dimmable LED driver, and the inverter is in emergency-mode, the inverter's 0-10 Vdc dimming circuit controls the dimmable LED driver's power level so that the total load on the inverter does not exceed 25 Watts. The maximum load power during normal-mode is 75 Watts. This feature allows the **ACI-G25-A1** to be connected to a single fixture or multiple parallel connected fixtures where the total power in normal-mode could exceed 25 Watts. The maximum load power during normal-mode is 125 Watts. For example, with the **ACI-G25-A1** connected to multiple parallel connected fixtures, such as five 10-Watt fixtures, then in emergency-mode, the **ACI-G25-A1** will automatically adjust the 0-10 Vdc dimming circuit voltage level of each fixture so that the total load on the inverter does not exceed 25 Watts. In this way, each of the 10-Watt fixtures will be operated at 5 Watts in emergency-mode. Note that, in normal-mode operation, the normal lighting functionality and the normal-mode dimming circuits are unaffected by the **ACI-G25-A1** and operate as normal.

Specifications:

Emergency lighting shall be provided by using the **ACI-G25-A1 emergency lighting inverter**. The **ACI-G25-A1** shall contain a lithium iron phosphate (LiFePO_4) battery, a high-efficiency battery charger, control circuitry, a high-efficiency two-wire universal input converter (120 through 277 Vac), and a high-efficiency pure sine wave power inverter, all contained in a single metal enclosure with dimensions 12.6 in L x 2.24 in W x 2.05 in H. The **ACI-G25-A1** shall have a maximum of 14 Watts input power. A miniature illuminated test switch status indicator shall be provided for the purposes of performing periodic testing and indicate status change of the battery and battery-charger. The **ACI-G25-A1** shall be capable of delivering 25 Watts at an output voltage of 120 Vac or 277 Vac, over a load PF range from 0.65 leading to 0.65 lagging, for a minimum of 90 minutes. The output voltage is automatically determined and automatically selected. The **ACI-G25-A1** shall be UL and cUL listed (UL 924) and shall meet or exceed the requirements of NFPA 101 Life Safety Code, NFPA 70 National Electrical Code, OSHA, and State and local codes. The **ACI-G25-A1** shall be CEC Title 20 compliant and listed in the California Energy Commission Title 20 Appliance Efficiency Database. The **ACI-G25-A1** shall comply with part 15 of the FCC Rules. The **ACI-G25-A1** is suitable for indoor and damp locations. The **ACI-G25-A1** shall be capable of operating in an ambient temperature of 0°C to 50°C .

5-Year USA-Backed Warranty*

See complete AC Warranty information for details

Warranty:

The **ACI-G25-A1** warranty is 5 years based on a maximum case temperature of $\leq 60^{\circ}\text{C}$, or 3 years warranty based on a maximum case temperature of $\leq 70^{\circ}\text{C}$.

For questions or to place an order contact us at oemsales@aceleds.com or 800-375-6355
or your local WPG Americas Sales representative at inquiry@wpgamericas.com or 888-WPG8881

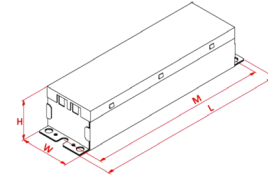
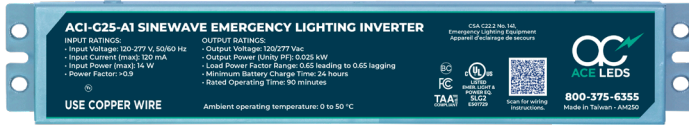

Enclosure:

Lead Lengths			
White	6"	Purple	6"
Yellow/Black	6"	Orange	6"
Black/Orange	6"	Gray	6"
Red/White	6"	Battery Connector	27.56"
Blue/White	6"	Test Switch	7.48"
Pink	6"	LED Indicator	23.62"

Dimensions			
Length (L)	20.67"	Height (H)	2.17"
Width (W)	2.24"	Mounting (M)	20.28"

NOTE: Test switch wiring can be extended up to 50'.

Wiring Diagrams for Operating One Single Fixture

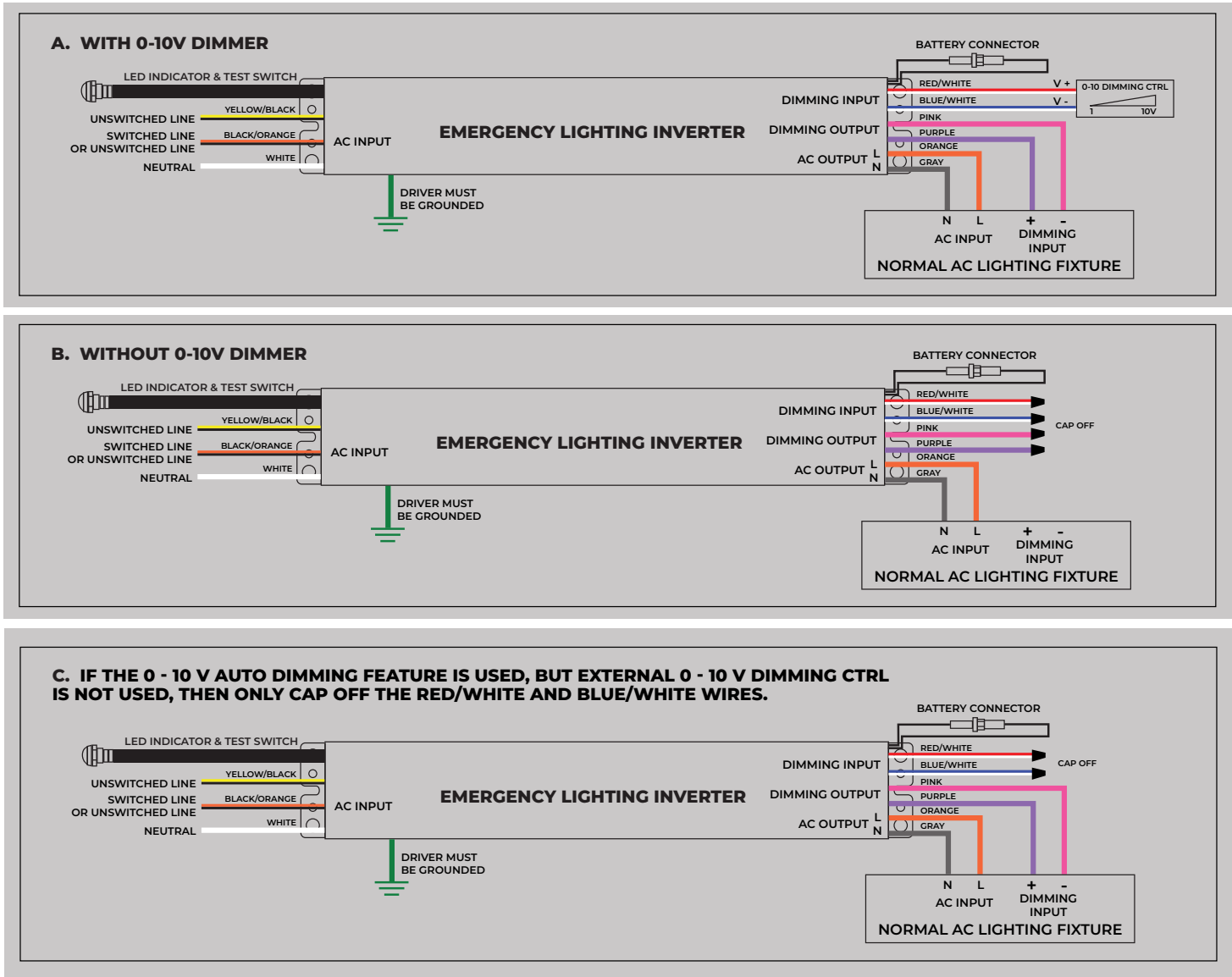

For questions or to place an order contact us at oemsales@aceleds.com or 800-375-6355 or your local WPG Americas Sales representative at inquiry@wpgamericas.com or 888-WPG8881

Wiring Diagram for Operating Multiple Fixtures

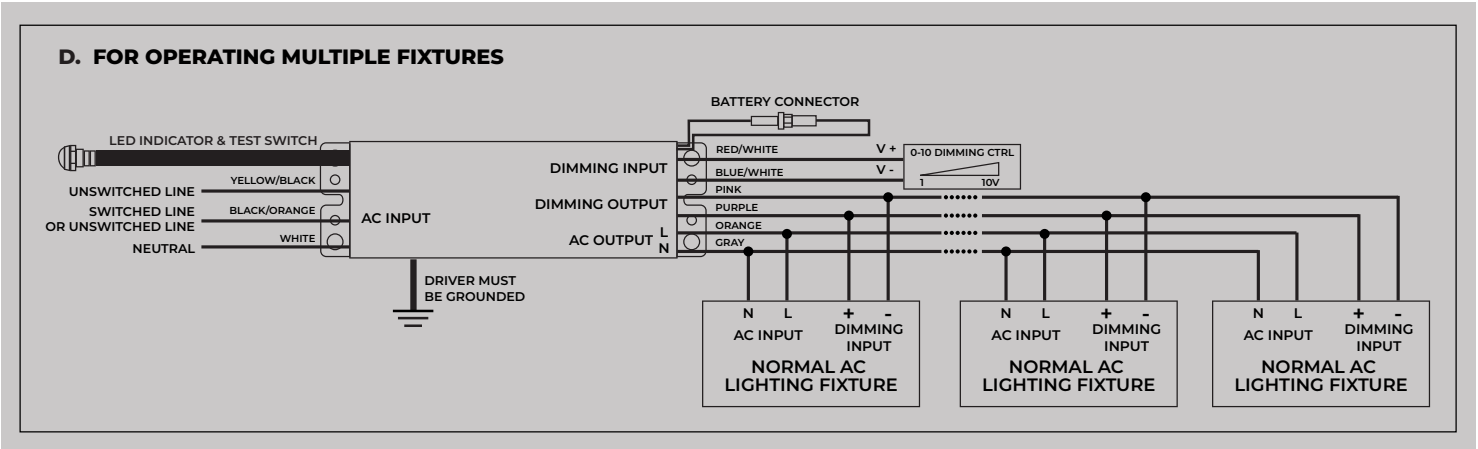

- A.) The wiring diagrams shown depict full functionality utilizing the 0 - 10 V Auto Dimming feature.
- B.) If the 0 - 10 V Auto Dimming feature is not used, cap off the RED/WHITE, BLUE/WHITE, PINK, and PURPLE wires.
- C.) If the 0 - 10 V Auto Dimming feature is used, but external 0 - 10 V Dimming CTRL is not used, then only cap off the RED/WHITE and BLUE/WHITE wires.

Fixture Load Configuration Type	Wiring Instructions
Switched: The Normal AC Lighting Fixture is utilized in both Normal-Mode and Emergency-Mode.	Connect the YELLOW/BLACK wire to the Unswitched Line, and connect the BLACK/ORANGE wire to the Switched Line
Normally On/always On/Unswitched	Connect the BLACK/ORANGE wire to the YELLOW/BLACK wire
Normally Off/Emergency-mode only	Cap off the BLACK/ORANGE wire

Inverter model, maximum inverter output power in emergency-mode, and maximum total load power in normal-mode:

Model	Maximum Inverter Output Power* (W) (Emergency-Mode)	Maximum Total Load Power** (W) (Normal-Mode)
ACI-G25-A1	25	125 (Note: The maximum total load power must not exceed 125 Watts. The inverter will only deliver a maximum of 25 Watts in emergency-mode.)

* **Note:** The maximum inverter output power (emergency-mode) is defined as the maximum output power that the inverter can deliver in emergency-mode.

** **Note:** The maximum total load power (normal-mode) is defined as the maximum total normal-mode steady-state long-term load power of all connected loads, while in normal-mode.

*AC Electronics/ACE LEDS warrants to the purchaser that each Emergency LED Driver will be free from defects in material or workmanship for a period of 5 years when operated at max case temp of up to <60°C and 3 years warranty based on a maximum case temperature of ≤ 70 °C when properly installed and under normal conditions of use. See aceleds.com for complete warranty policy.

For questions or to place an order contact us at oemsales@aceleds.com or 800-375-6355 or your local WPG Americas Sales representative at inquiry@wpgamericas.com or 888-WPG8881

ACE Emergency Inverter Automatic Power Share Table

The ACE LEDS ACI-G25-A1 Inverter Automatic Power Share Table

Rated Fixture Power (W)	5						10				
Number of Fixtures*	5	7	10	15	20	25	2	4	8	10	12
Dim: (%)**	100.0	71.4	50.0	33.3	25.0	20.0	100.0	62.5	31.3	25.0	20.8
Power per Fixture (W)	5.00	3.57	2.50	1.67	1.25	1.00	10.00	6.25	3.13	2.50	2.08
Light output (lm)***	595	425	298	198	149	119	1190	744	372	298	248

Rated Fixture Power (W)	15						20				
Number of Fixtures*	1	2	4	6	7	8	1	2	4	5	6
Dim: (%)**	100.0	83.3	41.7	27.8	23.8	20.8	100.0	62.5	31.3	25.0	20.8
Power per Fixture (W)	15.00	12.50	6.25	4.17	3.57	3.13	20.00	12.50	6.25	5.00	4.17
Light output (lm)***	1785	1488	744	496	425	372	2380	1488	744	595	496

Rated Fixture Power (W)	25				30				40		
Number of Fixtures*	1	2	4	5	1	2	3	4	1	2	3
Dim: (%)**	100.0	50.0	25.0	20.0	83.3	41.7	27.8	20.8	62.5	31.3	20.8
Power per Fixture (W)	25.00	12.50	6.25	5.00	25.00	12.50	8.33	6.25	25.00	12.50	8.33
Light output (lm)***	2975	1488	744	595	2975	1488	992	744	2975	1488	992

Rated Fixture Power (W)	50		60		80	100	
Number of Fixtures*	1	2	1	2	1	1	
Dim: (%)**	50.0	25.0	41.7	20.8	31.3	25.0	
Power per Fixture (W)	25.0	12.5	25.0	12.5	25.0	25.0	
Light output (lm)***	2975	1488	2975	1488	2975	2975	

The maximum output power (in emergency-mode) is 25 Watts, and is defined as the maximum output power that the inverter can deliver in emergency-mode.

* The Maximum Total Load Power (in Normal-Mode) is 125 Watts, and is defined as the maximum total normal-mode power of all connected loads while in normal-mode

** This value, expressed in percent, indicates the power level each fixture is operated at in emergency-mode relative to the fixture's rated power.

*** Lumen output values based on LED Driver Efficiency of 85%, and 140 Lm/W LED array Efficacy.

This chart assumes the proper operation of the automatic dimming control (0-10 Vdc) feature, and all connected fixtures are identical.

Note: For fixtures rated between power levels given, use the lesser power level given in the chart.

For questions or to place an order contact us at oemsales@aceleds.com or 800-375-6355 or your local WPG Americas Sales representative at inquiry@wpgamericas.com or 888-WPC8881